

Interactive Whiteboard

Touch-Sensitive Surface

Interact
Explore
Enlighten



Interactive Projection on a Touch-sensitive Surface



Optional Wireless Communication



Optional Enclosures and Mobile Stands

PolyVision's TS Series of Interactive Whiteboards is ideal for power users who prefer to learn product-specific software.

Keep Your Audience Focused

Dramatically improve group interactivity by allowing participants to listen and engage. PolyVision's TS series digitally captures any notes written or projected onto the board, so your audience can focus on the session content rather than concentrating on taking notes.

Maintain Message Consistency

There is little room for miscommunication when all session participants have the same notes; simply save your work to a computer for later distribution. Notes can be provided in your choice

of format: via e-mail, Internet, intranet, or printed copies.

Enjoy your Free Time

Projection-oriented users prefer a digital presentation format to a written format; often spending a lot of time creating an interactive experience for the audience. The TS series helps to eliminate the time crunch by capturing notes and annotations on projected images, so it's easy to review the notes made during previous sessions and digitally update presentations accordingly - an ideal solution for educators who specialize in one subject area.

TS Series Interactive Whiteboards: Present an interactive experience.

POLYVISION
A Steelcase Company

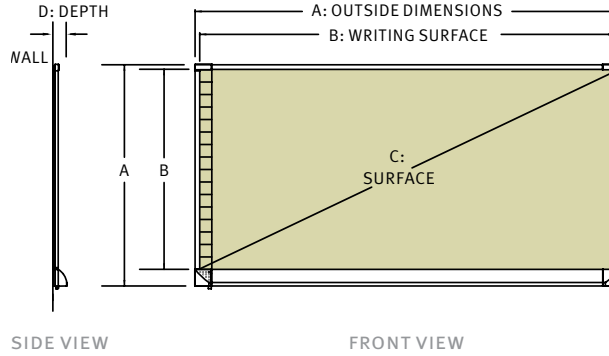

Interactive Whiteboard	Model TS 400	Model TS 600	Model TS 800
Dimension A (HxW)	39.7" x 47.0" (1010mm x 1190mm)	47.7" x 67.0" (1210mm x 1700mm)	47.7" x 97.0" (1210mm x 2460mm)
Dimension B (HxW)	35.0" x 45.0" (889mm x 1140mm)	43.0" x 65.0" (1090mm x 1650mm)	43.0" x 95.0" (1090mm x 2410mm)
Dimension C (Diagonal)	56.9" (1446mm)	77.8" (1976mm)	104.3" (2649mm)
Dimension D (Depth)	3.0" (76.2mm)	3.0" (76.2mm)	3.0" (76.2mm)
Resolution	8000 x 8000	8000 x 8000	8000 x 8000
Weight	30 lbs. (13.62 kg)	55 lbs. (24.97 kg)	70 lbs. (31.78 kg)

Surface material

Touch-sensitive, low-glare, stain-resistant Teflon® surface

Power Requirements

120V/240V wall mounted power supply 8VDC, 5W (max)

Certification

CE, FCC Class A

Software Features

- Transfer images via drag & drop, clipboard, or file export
- Anti-aliased markup including highlighters
- Real-time playback
- Multiple monitor support
- Save images in JPG, BMP, TIFF, WMF, HTM, PDF, PCT, MacPaint, PSD, PNG, Quicktime Image, and TGA

Warranty

Two-year limited warranty, free upgrade to five years upon product registration

Accessories (Included)

- Standard dry-erase markers in black, blue, red, and green
- 3.25" (830 mm) round eraser
- 12' (3.6m) 9-pin serial cable for TS 400; 20' (6.1m) for TS 600 and TS 800

Recommended Computer Requirements

Microsoft Windows®:
Pentium® processor, 32 MB RAM
Windows 98, NT, 2000, ME, XP
Serial port with 9-pin D-type male connector

Apple Macintosh®:

Powerbook®, G3, G4, iBook®, iMac™, eMac™
32 MB available RAM
Available serial port or use optional USB to 9-pin serial adapter
Mac OS version 8, 9, or X

Options

- Serial 9-pin to USB adapter
- Mobile stand - supports models TS 400 and TS 600
- PenOffice™ Handwriting Recognition Software
- Room-blasting, infrared wireless computer connection

Authorized PolyVision Dealer

PolyVision Corporation
1.800.620.POLY
info@polyvision.com
www.polyvision.com

POLYVISION
A Steelcase Company